



WINDSEAL™

MAGNETIC DRAFT COVER

DESIGNED IN THE WESTERN CAPE.
BUILT FOR THE SOUTH EASTER.

INSTALLATION GUIDE

Thank you for choosing the WindSeal Magnetic Draft Cover.

Scan the QR code to view the installation instructions on the WindSeal website.



TOOLS REQUIRED



5 mm Drill Bit



Pop Rivet Gun



Cordless Drill



Safety Glasses

PACKAGE CONTENTS

- 1 WindSeal Magnetic Draft Cover (with 2 pre-installed flat disc magnets)
- 2 2 x Countersunk Neodymium Magnets
- 3 2 x 4.8 x 15 mm Countersunk Blind Rivets

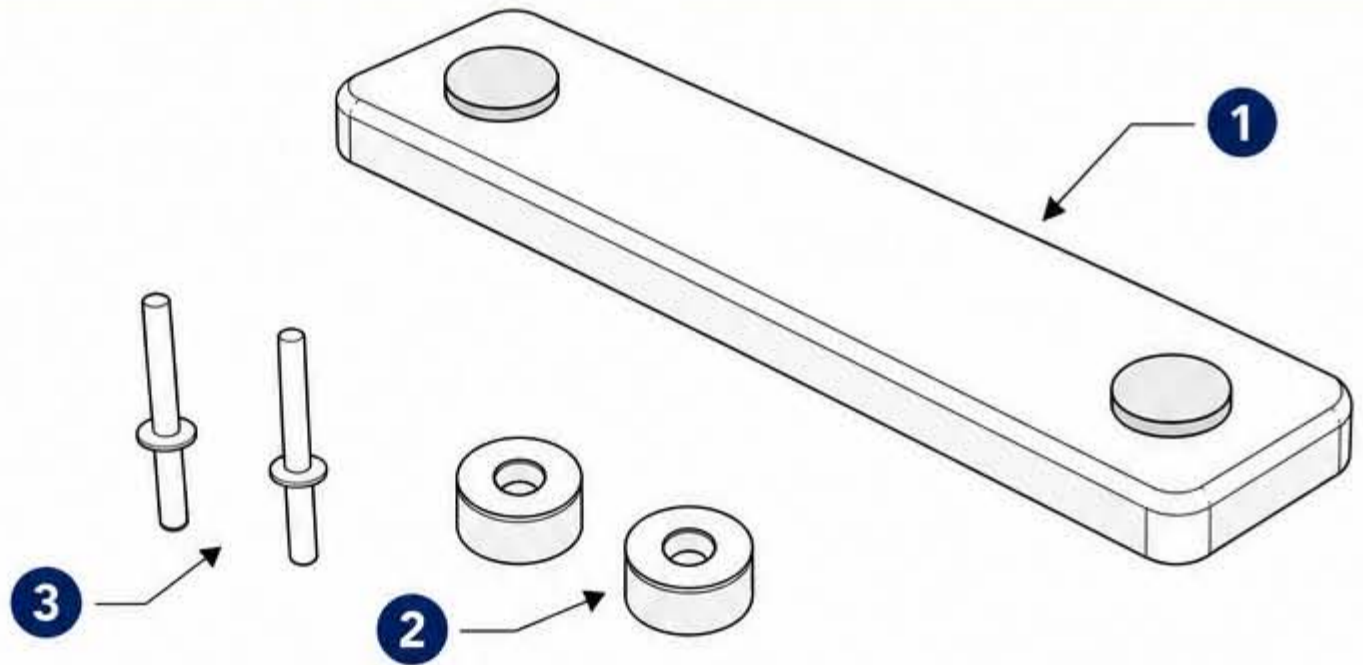

STEP 1

Remove the existing top and bottom latch rivets using a 5 mm drill bit.

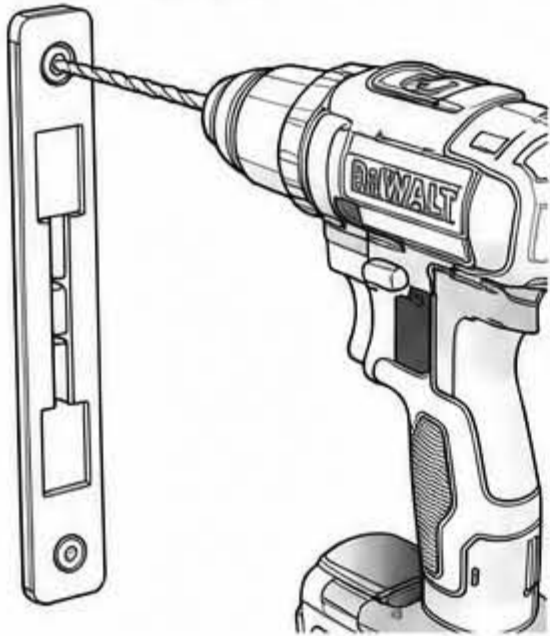

STEP 2

Install the supplied countersunk magnets using the supplied blind rivets and a pop rivet gun.

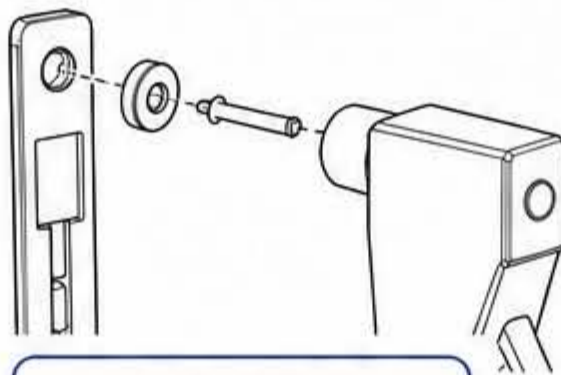

IMPORTANT

Install each magnet with the countersunk face towards the rivet head.

STEP 3

Position the WindSeal cover over the installed magnets until it snaps securely into place.

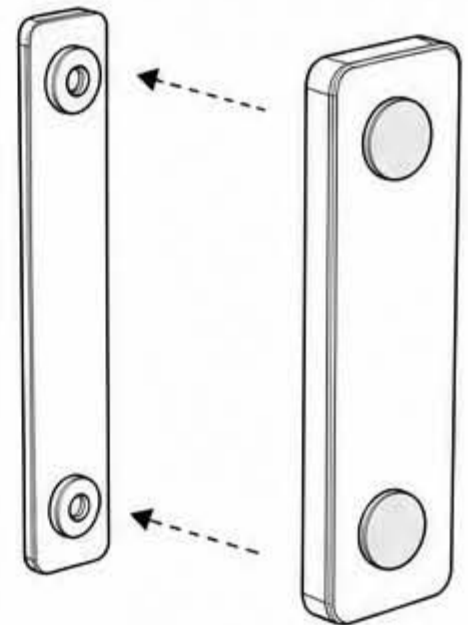

WARNING – CONTAINS STRONG NEODYMIUM MAGNETS

- Keep away from children.
- Keep away from pacemakers and implanted medical devices.
- Keep away from magnetic storage media, bank cards and sensitive electronics.
- Swallowed magnets can cause serious internal injury. **Seek immediate medical attention**

INSTALLATION DISCLAIMER

WindSeal shall not be liable for any injury, damage or loss resulting from incorrect installation, misuse, modification of the product, or failure to follow these installation instructions.

The installer is responsible for ensuring that the product is suitable for the intended application and is installed correctly.



www.windseal.co.za



sales@windseal.co.za